

4781 0243

**EXHIBIT "A"**

**Legal Description: Site Plans: Unit Plans**

Being Lot 1 Block 1 of GABLES AT PRESTON, an Addition to the City of Plano, Collin County, Texas, according to the Plat thereof recorded in Volume J, Page 176, Map Records, Collin County, Texas.

4781 0244

FILE # 100/00/0000000000

100/00/00/0000000000  
100/00/00/0000000000  
100/00/00/0000000000

PRESTON ROAD

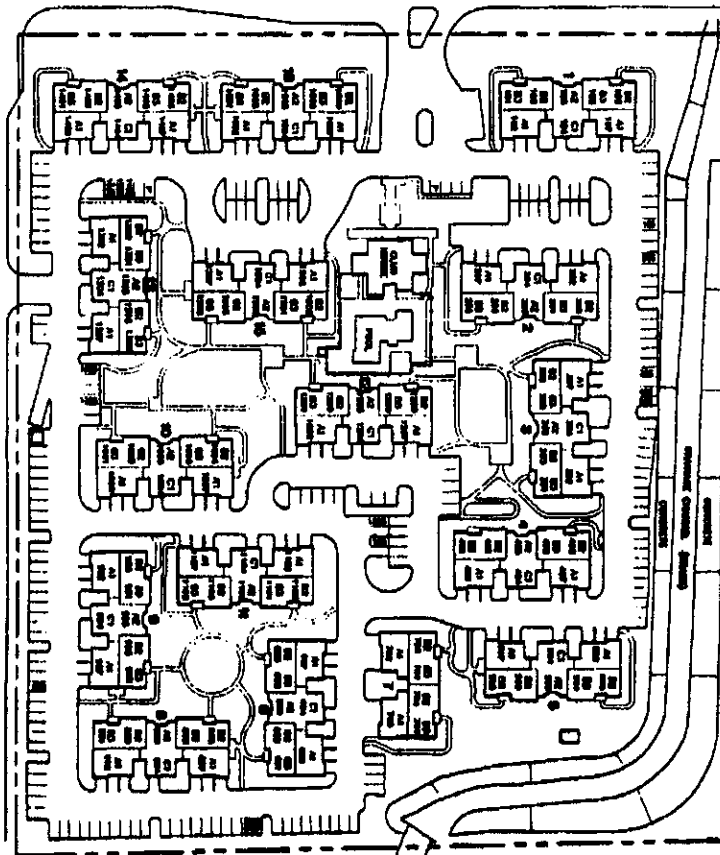

THE APPROVAL OF PRESTON PARK CONDOMINIUM  
100/00/00/0000000000  
100/00/00/0000000000  
100/00/00/0000000000



4781 0245

FILE: 01/00/01/0400000000

NOTES:  
DIMENSIONS SHOWN HAVE BEEN APPROXIMATELY  
FIELD MEASURED.  
DIMENSIONS ARE REGARDED FROM THE  
CORNER OF THE WALLS

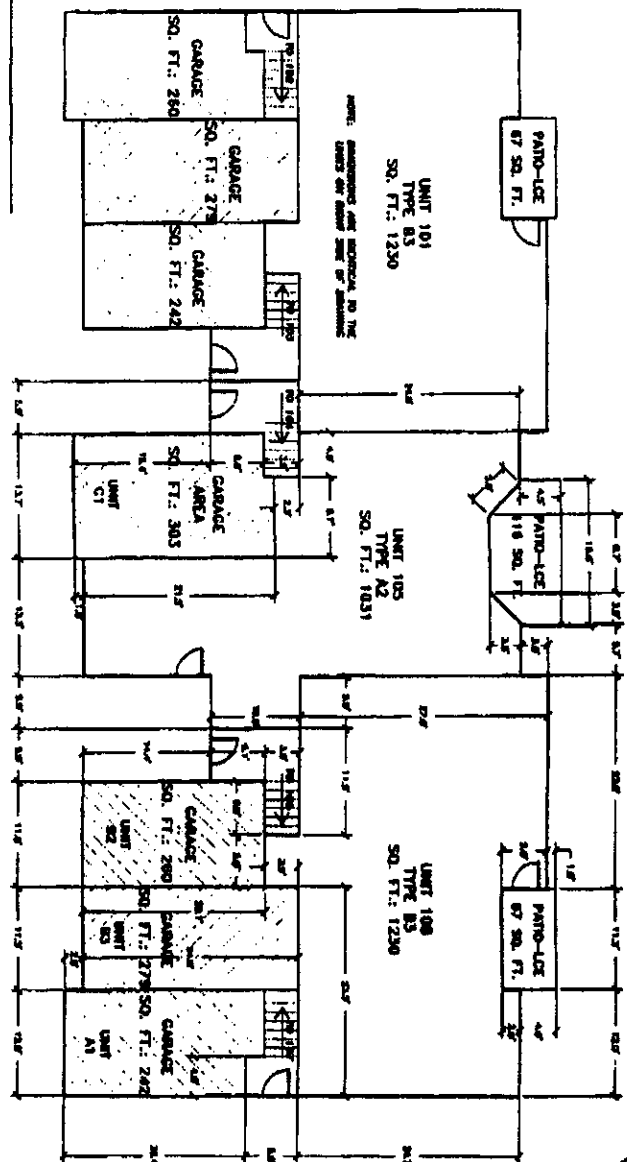

9 3 10 011  
 01/00/01/0400000000  
 THE BARONS OF FRESHMAN PARK CONDOMINIUMS  
 304 FRESHMAN PARK  
 PLAINVILLE, CT 06061  
 BUILDING No. 1 - LOWER LEVEL

4781 0246

FILE: 64\MS\DWG\40000007.DWG

NOTES:  
 DIMENSIONS SHOWN HAVE BEEN RANDOMLY  
 FIELD VERIFIED.  
 DIMENSIONS ARE MEASURED FROM THE  
 CENTER OF THE WALLS

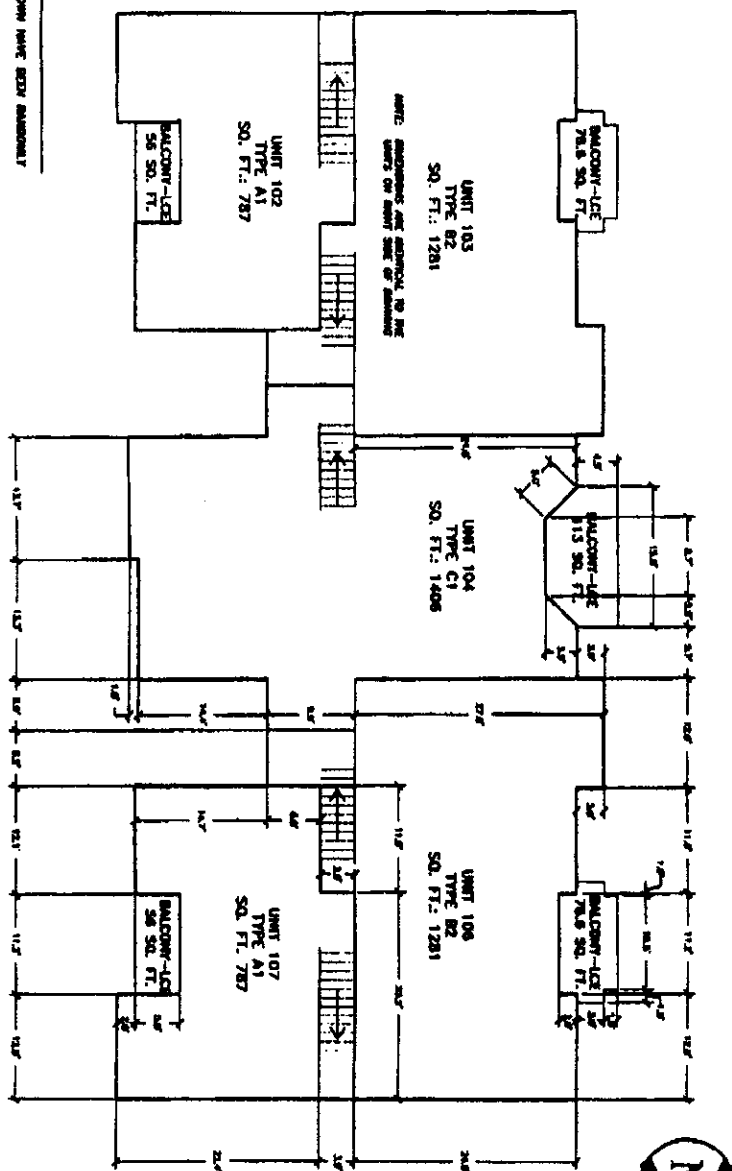

<p>1 1/8" = 1' 0" IN PLAN          DIMENSIONS IN FEET          DIMENSIONS ARE MEASURED FROM THE CENTER OF THE WALLS</p>		<p>THE MANAGER OF FREIGHT PLAN CONDOMINIUMS          4000 UNIVERSITY BLVD          PALM BEACH, FLORIDA 33480  <b>BUILDING No. 9 - 9TH LEVEL</b></p>
---	--	---

4781 0247

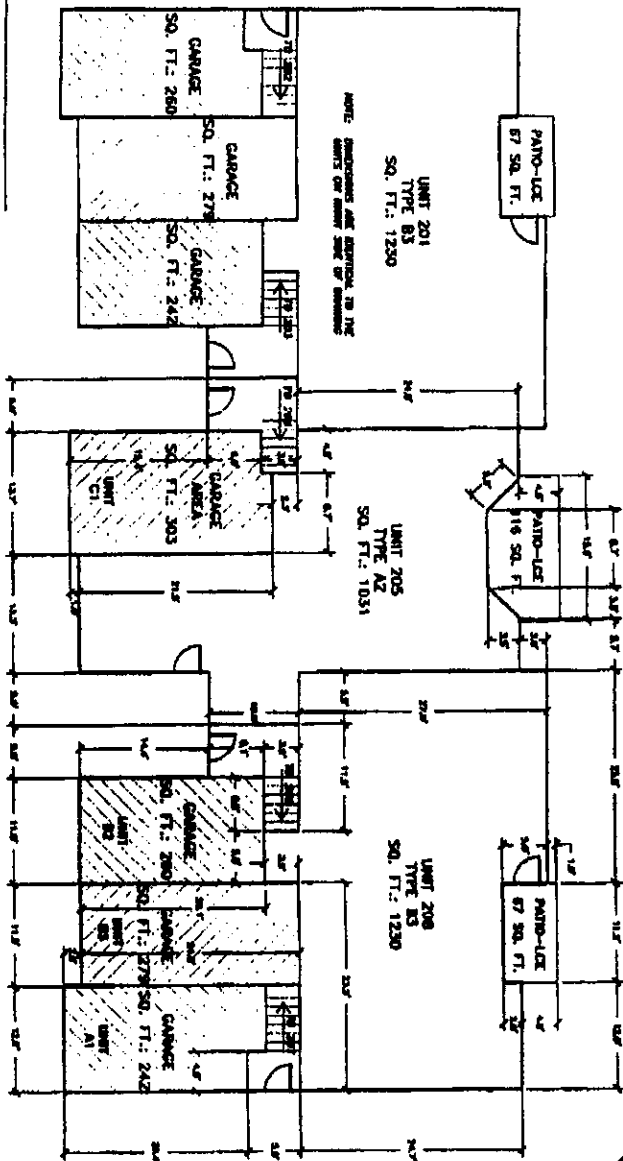

NOTES:  
 DIMENSIONS SHOWN HAVE BEEN MEASURED IN FIELD WORKMEN.  
 DIMENSIONS ARE MEASURED FROM THE CENTER OF THE WALLS.

<p>1/8" = 10 FEET</p> <p>SCALE BAR</p> <p>DATE PREPARED: 10/10/08</p>	<p>THIS GARAGE IS FREEMAN PARK CONDOMINIUMS</p> <p>1001 FREEMAN PARK</p> <p>PLANNING BOARD</p> <p>APPROVED: 10/10/08</p>
---	--

4781 0248

FILE NO. 10101001001001001001

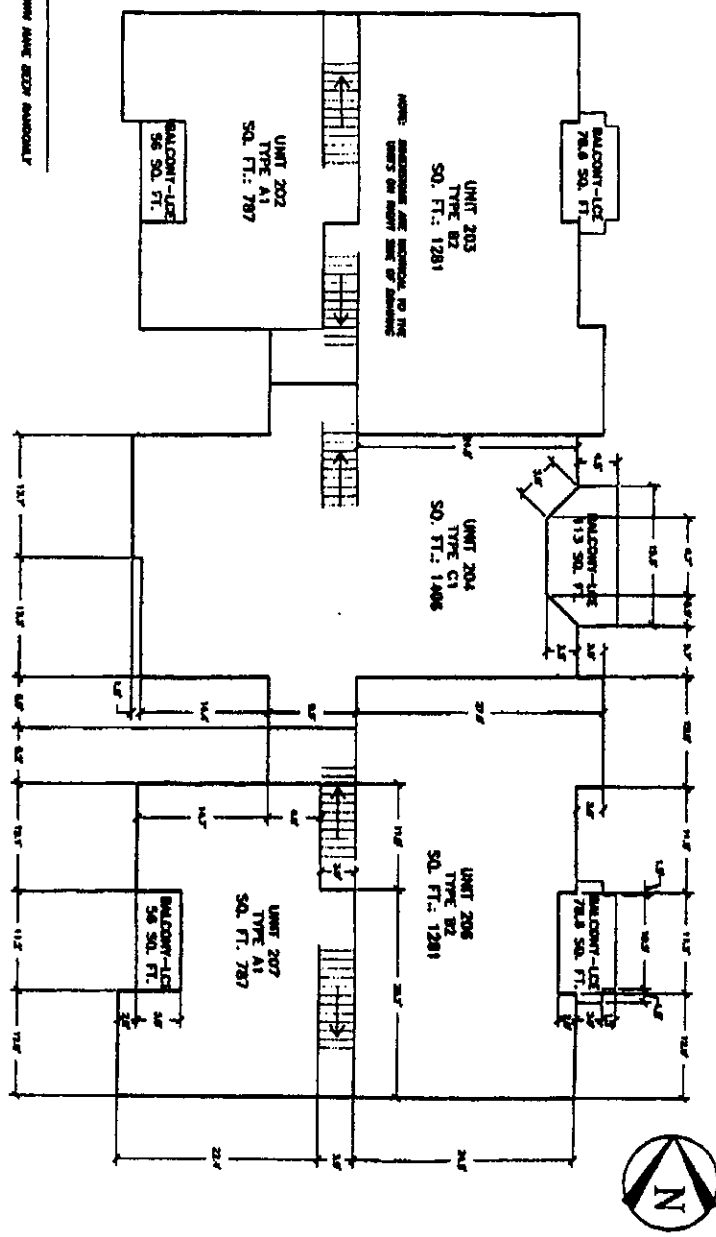

**NOTES:**  
 DIMENSIONS SHOWN HAVE BEEN MEASURED  
 FIELD VERIFICATION.  
 DIMENSIONS ARE MEASURED FROM THE  
 CENTER OF THE WALLS

0 3 1/4 FEET  
 SECTION SCALE

THE OFFICE OF PROVISION FROM CONSTRUCTION  
 AND PROVISION FROM  
 PLANNING DIVISION  
 BUILDING DIV. 2 - BUREAU LEVEL

ENC. Project No. 47810248

6420 1874

DATE: 01/15/2010 10:45 AM

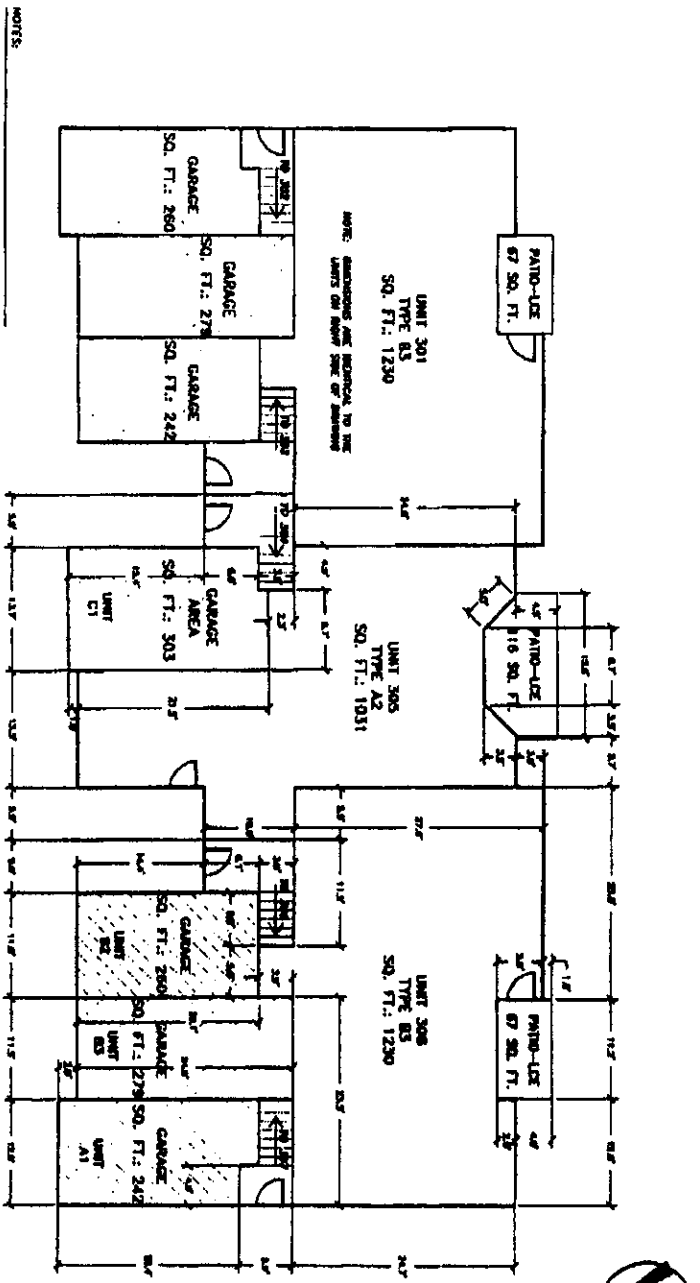

NOTES:

DIMENSIONS SHOWN HAVE BEEN APPROXIMATELY FIELD VERIFIED.

DIMENSIONS ARE MEASURED FROM THE CENTER OF THE WALLS

0 5 10 FEET

SCALE

THE MEMBERS OF PRINCETON PARK CONDOMINIUMS

3001 PRINCETON PARK

PRINCETON, NEW JERSEY

RESIDING IN: 3 - LOWER LEVEL

4781 0250

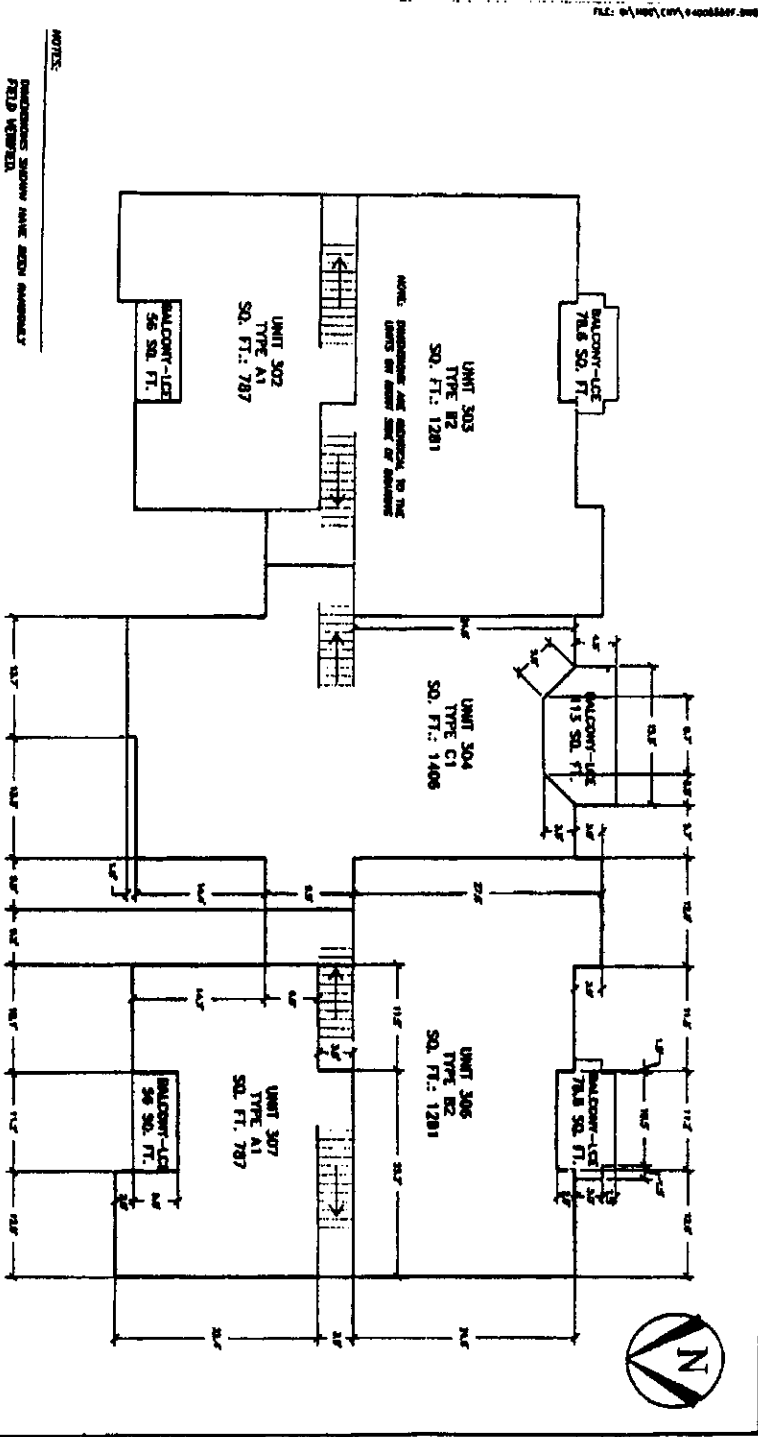

NOTES:  
DIMENSIONS SHOWN HAVE BEEN VERIFIED  
FIELD SURVEY  
DIMENSIONS ARE ASSUMED FROM THE  
CENTER OF THE WALLS



4781 0251

02/28/2000 10:00:00 AM

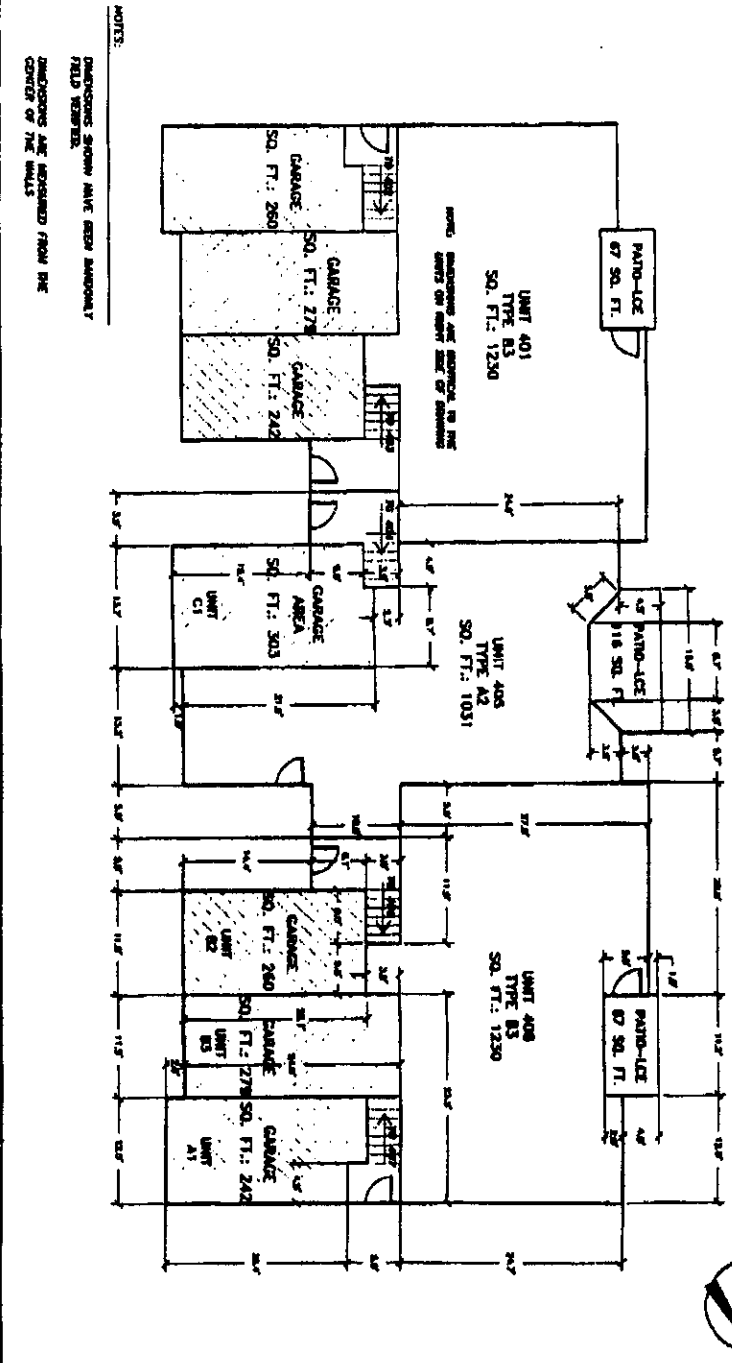

NOTES:  
DIMENSIONS SHOWN HAVE BEEN MANUALLY  
FIELD VERIFIED.  
DIMENSIONS ARE MEASURED FROM THE  
CENTER OF THE WALLS

0 1/4" = 1'-0"  
SCALE  
DATE: 02/28/2000

THE BRANDS OF FRANKLIN PARK CONDOMINIUMS  
404 FRANKLIN PARK  
FLANN VALLEY  
SHELBYVILLE, KY - LOWER LEVEL

4781 0252

NOTES:  
DIMENSIONS SHOWN HAVE BEEN INDEPENDENTLY  
FIELD VERIFIED.  
DIMENSIONS ARE WASTED FROM THE  
CENTER OF THE WALLS.

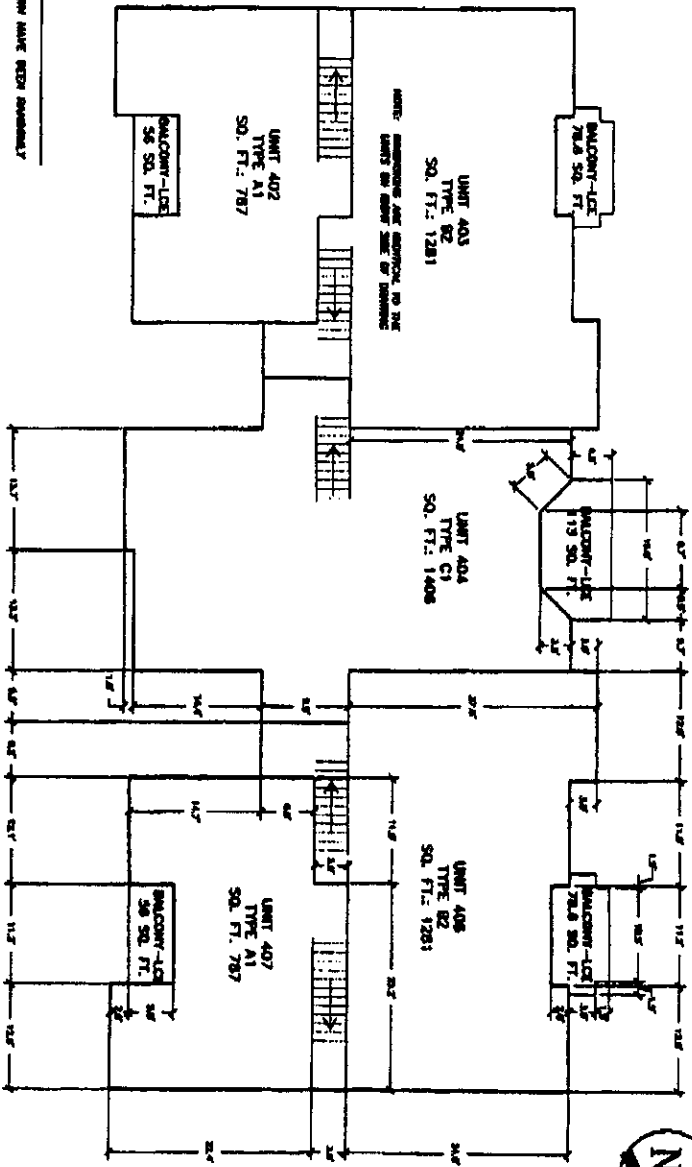

Scale: 1/8" = 1'-0"  
DATE: 11/10/07

THIS DOCUMENT IS PRELIMINARY AND NOT FOR CONSTRUCTION  
DRAWING NO. 4 - UPPER LEVEL

4781 0253

FILE: 04/20/2004 10:10:27 AM

NOTES:  
DIMENSIONS SHOWN HAVE BEEN MEASURED  
FIELD WORKING.  
DIMENSIONS ARE MEASURED FROM THE  
CORNER OF THE WALLS

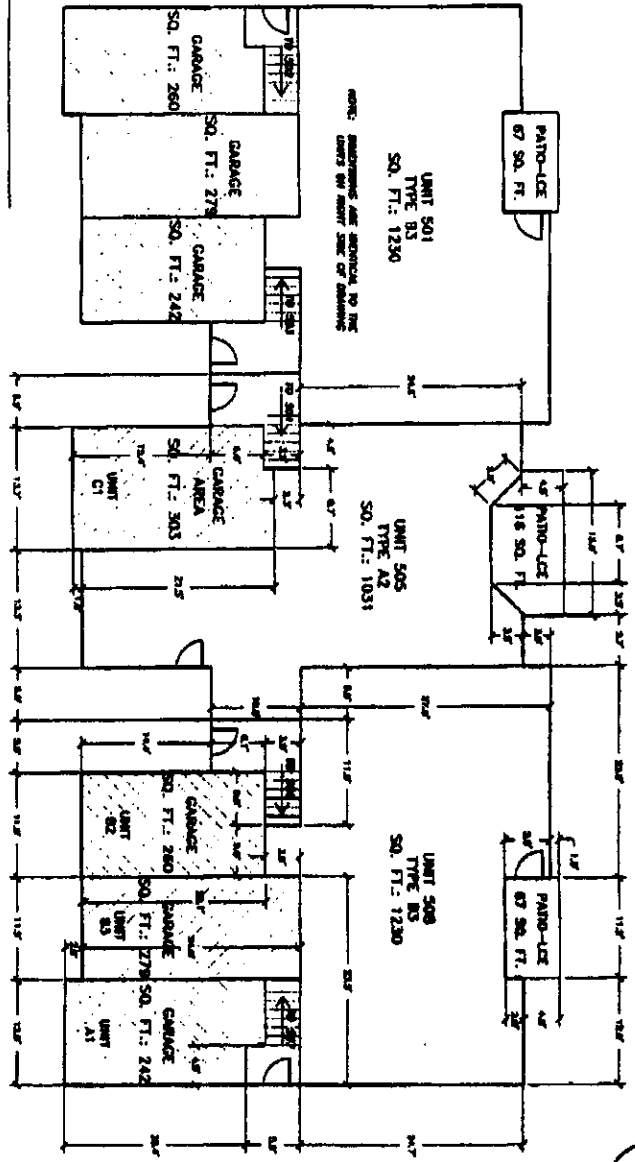

1/8" = 1' - 0" PLAN  
 0/8" = 1' - 0" SECTION  
 SEE PROJECT FILE 47810253

THE ARCHITECT IS PROVIDING PLANS FOR INFORMATION ONLY.  
 THIS PLAN IS NOT TO BE USED FOR CONSTRUCTION.  
 SEE ARCHITECT'S OFFICE FOR MORE INFORMATION.

4781 0254

FILE NO. 87-100-010-010-010-010-010

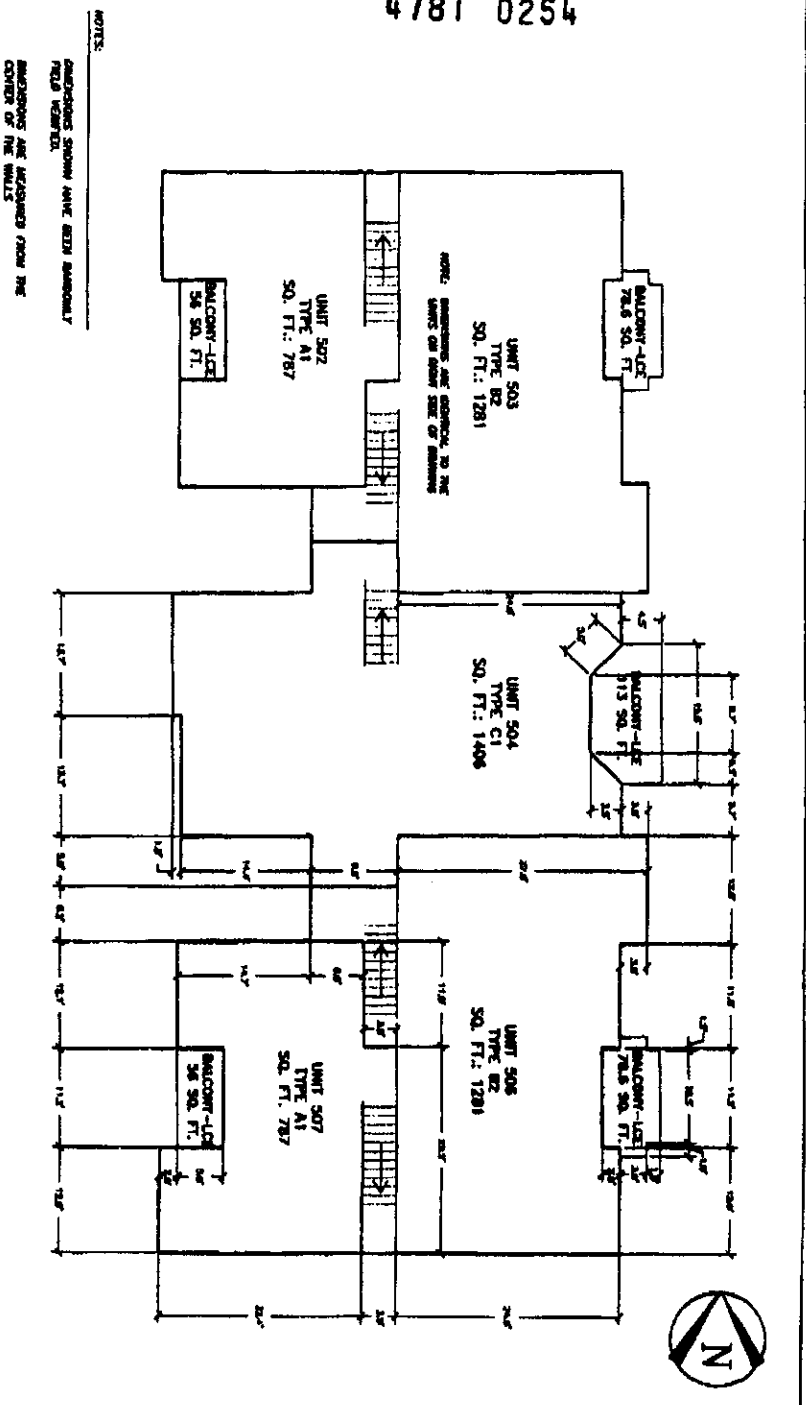

0 1/8" = 1' 0" SCALE  
PROJECT NO. 4781 0254

THE BOARD OF FREEDOM PARK COMMUNITIES  
3000 FREEDOM PARK  
PLAZA, WASHINGTON, D.C. 20008

DESIGNED BY: S. S. WYLER ARCHITECTS

4781 0255

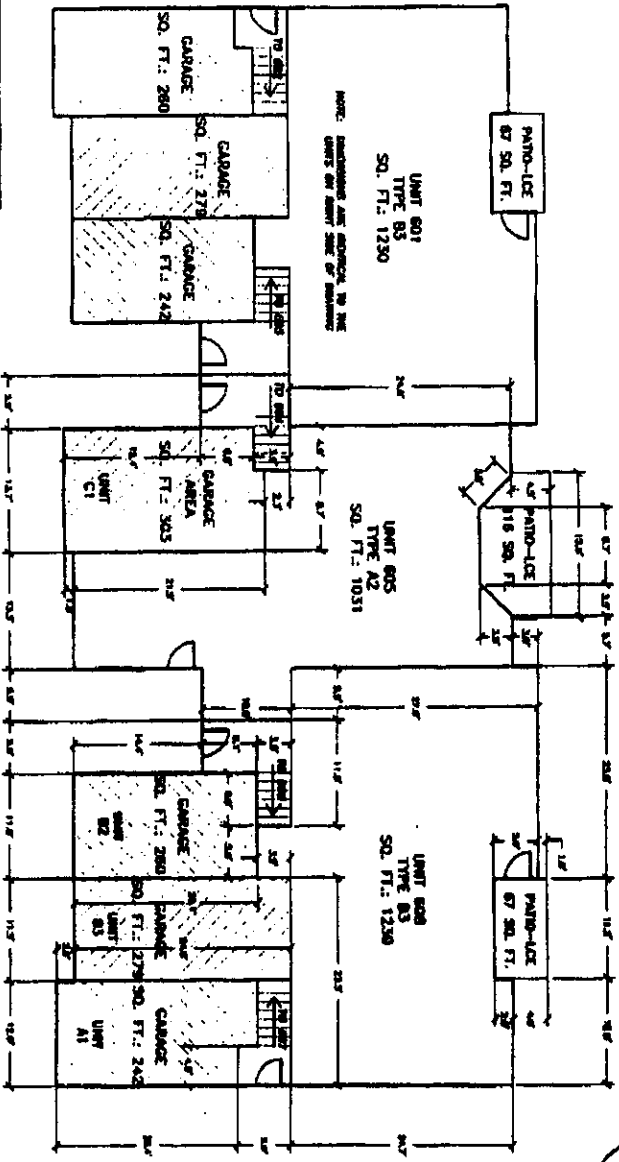

NOTES:

1. DIMENSIONS SHOWN HAVE BEEN MEASURED IN THE FIELD VERIFIED.

2. DIMENSIONS ARE MEASURED FROM THE CENTER OF THE WALLS.

0 1/4" = 10 FEET

PROJECT NO. 4781 0255

THE SERVICES OF PRESTON PARK CONDOMINIUMS

3000 UNIVERSITY AVENUE

ALABAMA 36688

PRELIMINARY PLAN

REVISIONS NO. 0 - LOWER LEVEL

4781 0256

FILE: 01/10/02/11/17/14/0200000000000000

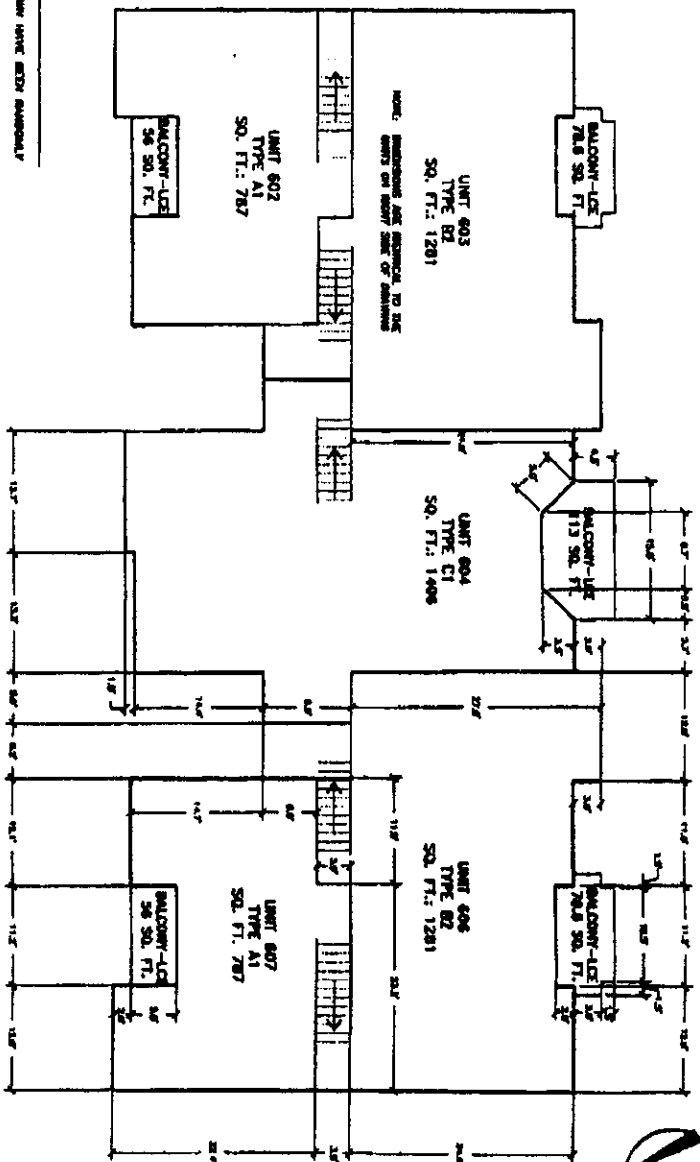

NOTES

DIMENSIONS SHOWN HAVE BEEN MEASURED IN THE FIELD. MEASUREMENTS ARE MEASURED FROM THE CENTER OF THE WALLS.

DESIGNED BY  
**DECA**  
 1500 PINE BLVD. SUITE 200  
 FARMINGTON, CT 06030

THE LANDLORD OF FRESHTON PARK CONDOMINIUMS  
 1500 PINE BLVD SUITE 200  
 FARMINGTON, CT 06030  
 DEVELOPER: DECA - 1500 PINE BLVD.

4781 0257

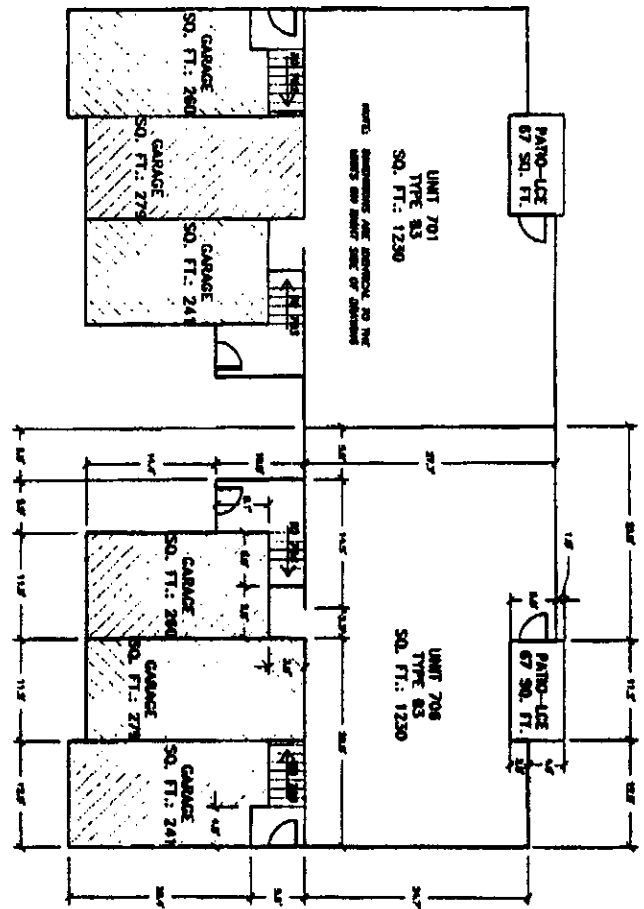

NOTES:

DIMENSIONS SHOWN HAVE BEEN HAND-DRAWN  
FIELD MEASUREMENTS.

DIMENSIONS ARE MEASURED FROM THE  
CENTER OF THE WALLS

9 - 1/4" = 1' 0"  
SECTION 101

THE GARAGES AT PINEBROOK PARK CONDOMINIUMS  
AND APARTMENTS  
PLAN NO. 101

BUILDING No. 7 - LOWER LEVEL

4781 0258

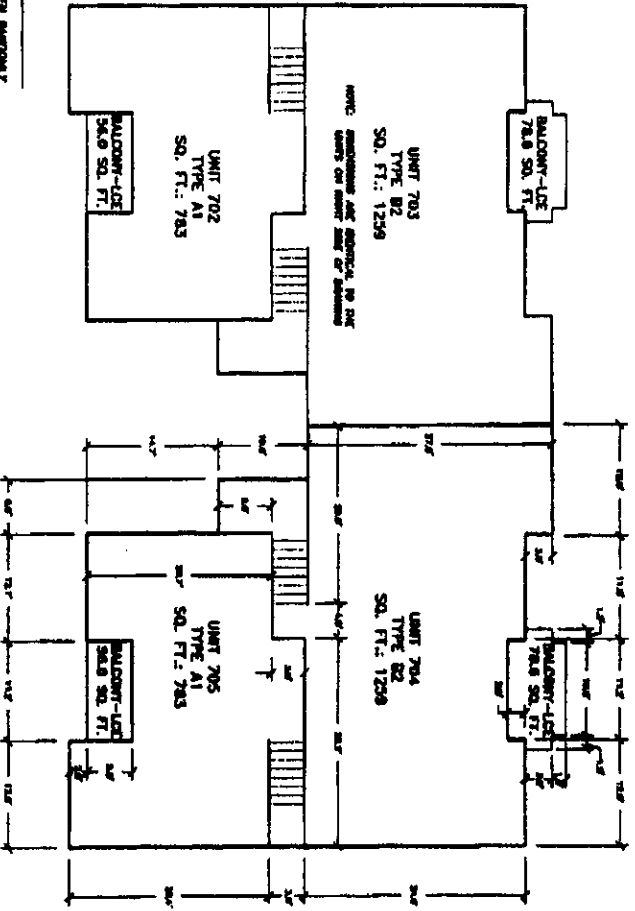

NOTES:  
DIMENSIONS SHOWN HAVE BEEN HAND-DRAWN  
FIELD WORKMEN.  
DIMENSIONS ARE MEASURED FROM THE  
CENTER OF THE WALLS

0 1 1/2 3 1/2 6 12  
INCHES  
FOOT SCALE

THE APARTMENTS OF PINEVIEW PARK CONDOS/CO-OP  
3841 PINEVIEW DRIVE  
PINEVIEW, TEXAS 75159  
BUILDING No. 7 - UPPER LEVEL.



4781 0259

FILE: G:\MCD\DW\44000000.dwg

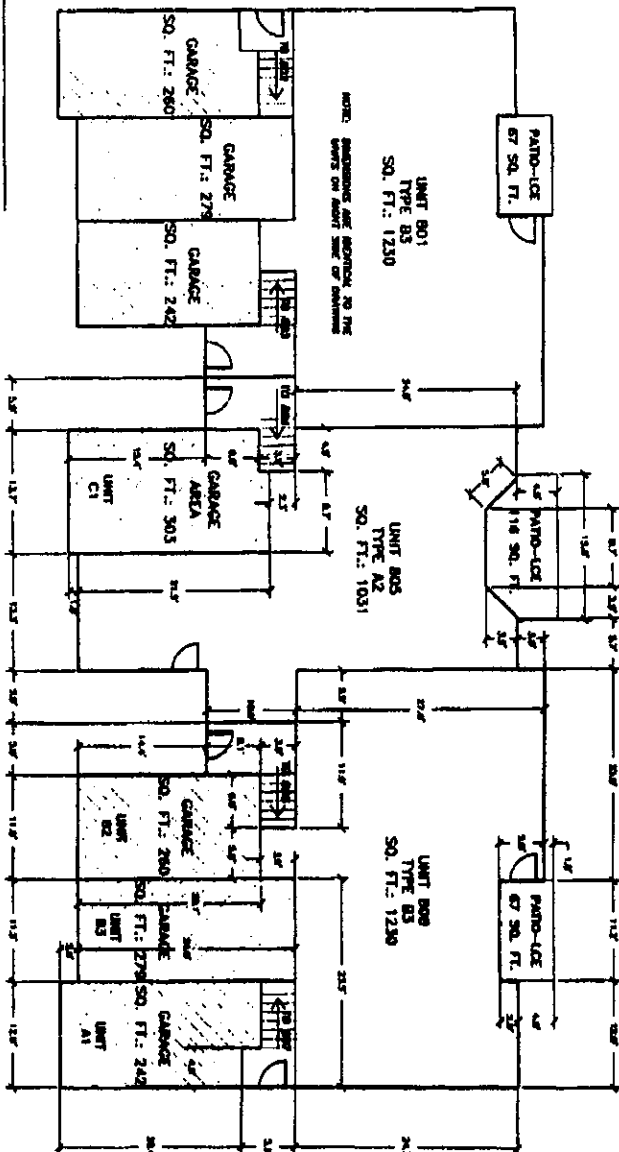

NOTES:  
 DIMENSIONS SHOWN HAVE BEEN APPROXIMATELY  
 FIELD MEASURED.  
 DIMENSIONS ARE MEASURED FROM THE  
 CENTER OF THE WALLS

0 5 10 FEET  
 DIMENSION SCALE

THE ARCHITECT AT FREESTON PARK CONDOMINIUMS  
 3000 FREESTON PARK  
 PLAZA, SUITE 100  
 BIRMINGHAM, AL 35243  
 DRAWING No. 9 - LOWER LEVEL

4781 0260

FILE NO. 100-1000000000

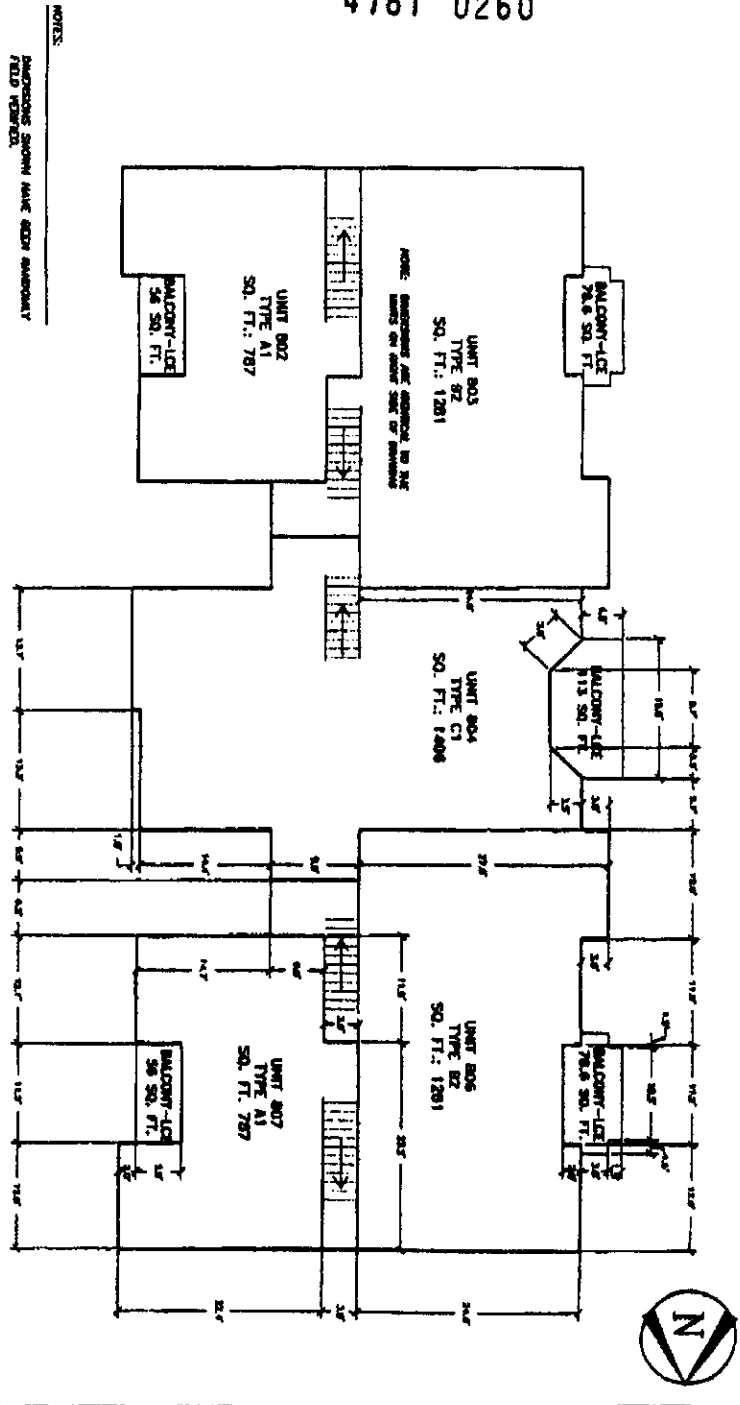

THE MANAGERS OF WASHINGTON PARK COMMONS  
5041 WASHINGTON ROAD  
FLANN, VIRGIL

REVISION NO. 9 - UPPER LEVEL

4781 0261

FILE: 01/10/01/01/00000001.dwg

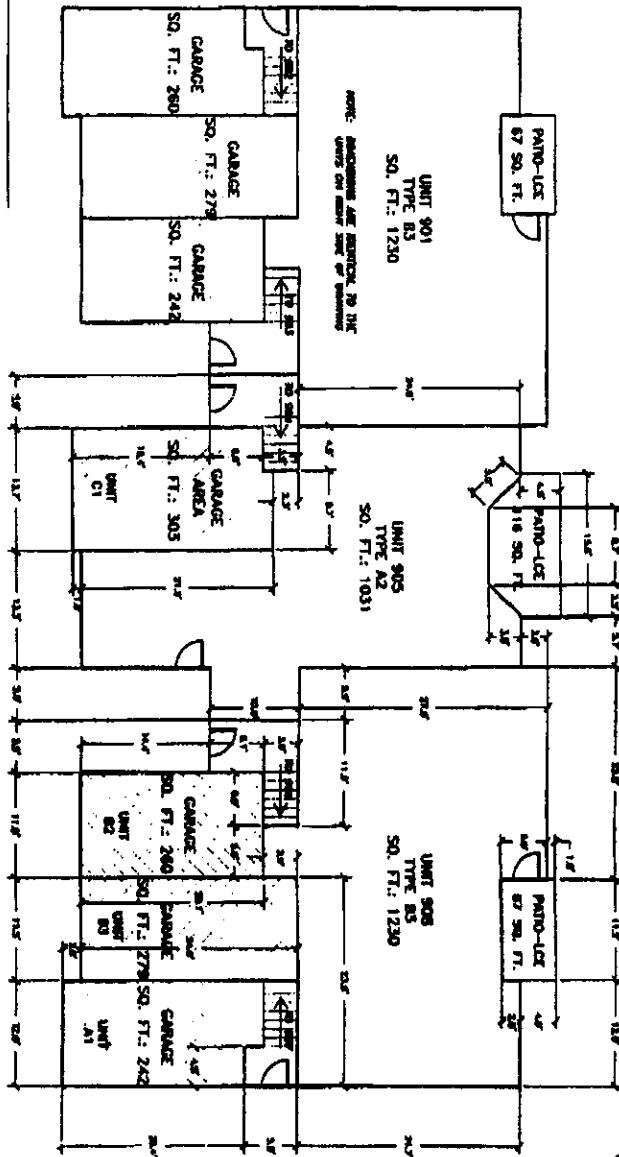

**NOTE:**  
DIMENSIONS SHOWN HAVE BEEN MANUALLY  
FIELD VERIFIED.  
DIMENSIONS ARE MEASURED FROM THE  
CENTER OF THE WALLS.

0 10 FEET  
DIMENSION LINE  
DIMENSION

INC. Project No. 00000000

THE ARCHITECT IS PROVIDING THESE CONSTRUCTION  
DRAWINGS FOR THE PROJECT AND  
PLANNING SERVICES.  
BUILDING No. 9 - LOWER LEVEL



4781 0262

FILE: 04/1982/004/0-40000007200

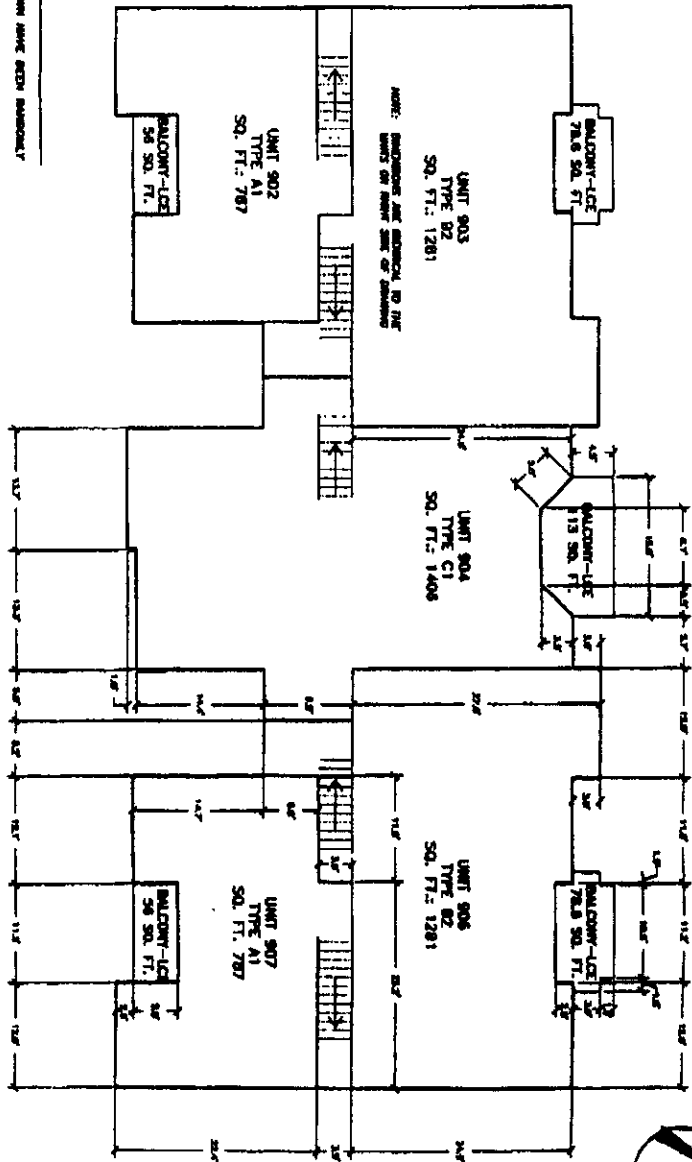

NOTES:  
DIMENSIONS SHOWN HAVE BEEN MEASURED IN THE FIELD WORKED.  
DIMENSIONS ARE MEASURED FROM THE CENTER OF THE WALLS.

0 2 1/2 IN. FEET  
SCALE  
DATE: 10/19/82  
BY: [illegible]

THE MATERIALS OF FINISHES FROM CONSTRUCTION  
AND FINISHES FROM  
PLANS SHALL  
BE SHOWN IN THE 3 - UPPER LEVELS

4781 0263

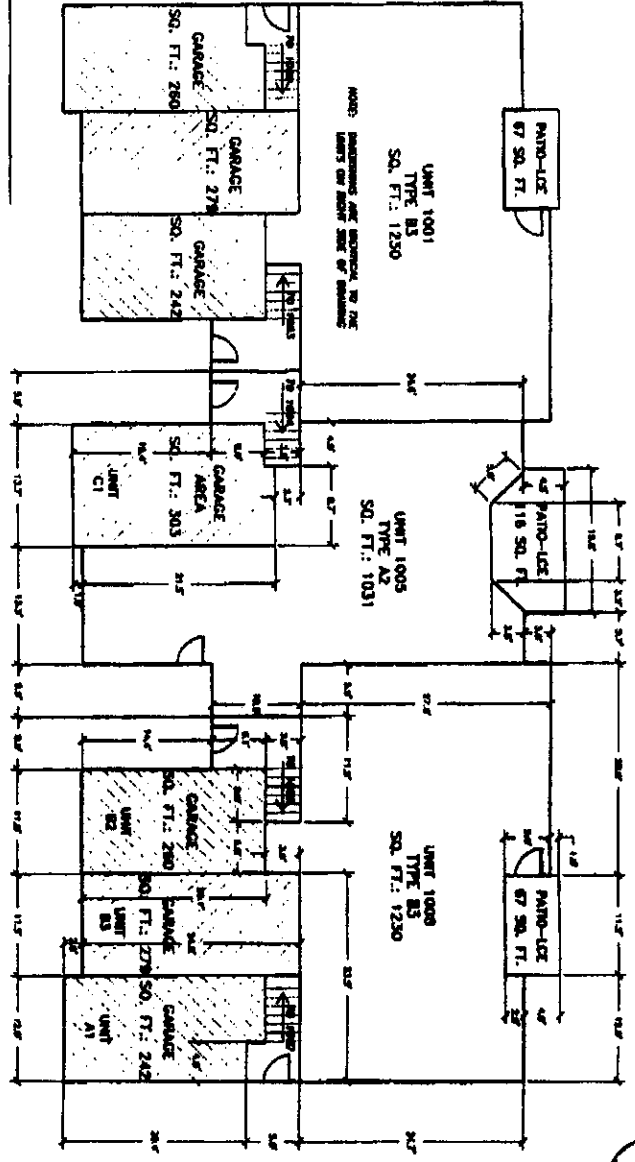

NOTES:  
 DIMENSIONS SHOWN HAVE BEEN MANUALLY  
 FIELD VERIFIED.  
 DIMENSIONS ARE MEASURED FROM THE  
 CENTER OF THE WALLS.

0 5 = 10 FEET  
 DIMENSIONS ARE MEASURED FROM THE  
 CENTER OF THE WALLS

THE ARCHITECTS AT PRINCETON PARK CONDOMINIUMS  
 2000 PRINCETON PARK  
 PRINCETON, NJ 08542  
 DRAWING NO. 30 - LOWER LEVEL

4781 0264

REF: 10/10/78

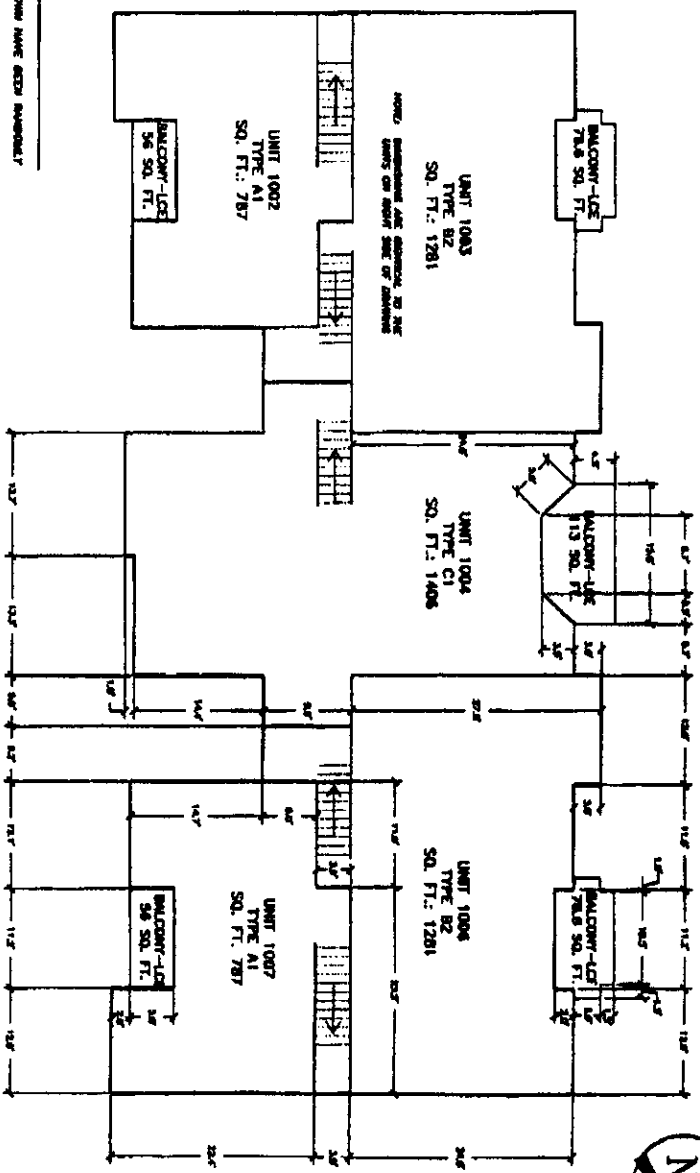

**NOTES:**  
 BALCONIES SHOWN HAVE BEEN MEASURED  
 FIELD VERIFIED  
 DIMENSIONS ARE ASSUMED FROM THE  
 CENTER OF THE WALLS

0 3 10 1987  
 PREPARED BY  
 THE ARCHITECTS OF PRINCETON PARK CONDOMINIUM  
 2000 PRINCETON PARK  
 PLAZA, NEWARK  
 NEW JERSEY 07102

4781 0265

FILE: 01/10/02/001/100000000000

NOTES:

DIMENSIONS SHOWN HAVE BEEN HAND-DRAWN  
FIELD VERIFIED.  
DIMENSIONS ARE MEASURED FROM THE  
CENTER OF THE WALLS

0 3 1/4 FEET  
SCALE  
PROJECT NO. 4781 0265  
DATE: PROJECT NO. 4781 0265

THE ARCHITECTS OF WESTON PARK CONDOMINIUMS  
1000 WESTON PARK DRIVE  
PLANO, TEXAS  
DRAWING NO. 01 - LOWER LEVEL

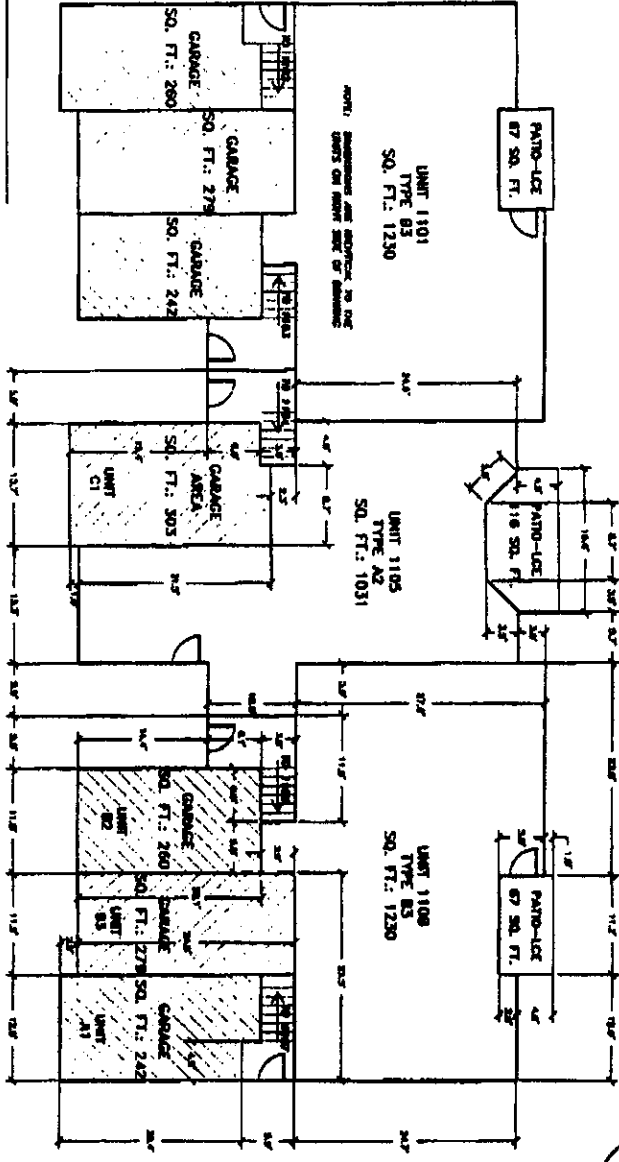

4781 0266

FILE NO. 100-100000-1000

NOTES:  
DIMENSIONS SHOWN HAVE BEEN APPROVED  
FIELD VERIFY.  
DIMENSIONS ARE MEASURED FROM THE  
CENTER OF THE WALLS

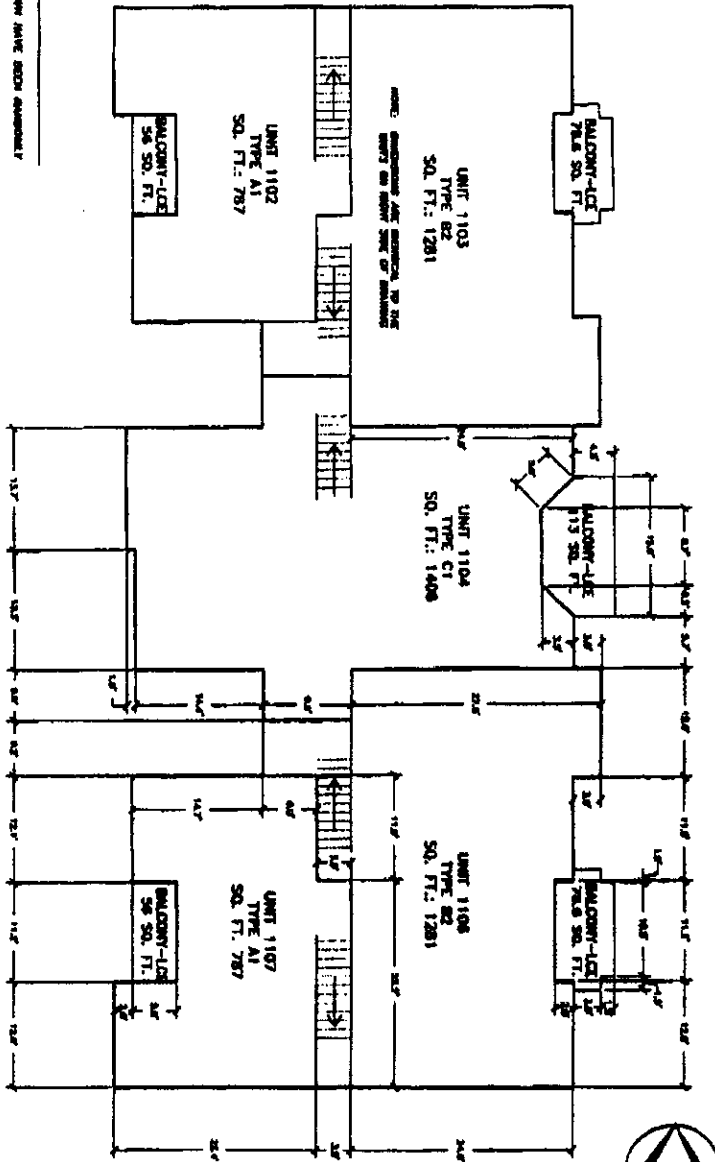

9 5 1/2 IN. UNIT  
 PRELIMINARY  
 100 Product Data Bookings

THE INFORMATION IS PRESENTED AS PRELIMINARY INFORMATION AND IS NOT TO BE USED FOR CONSTRUCTION OR FOR ANY OTHER PURPOSE.  
 CONSULT THE ARCHITECT FOR MORE INFORMATION.

DATE: 10/15/2010



4781 0267

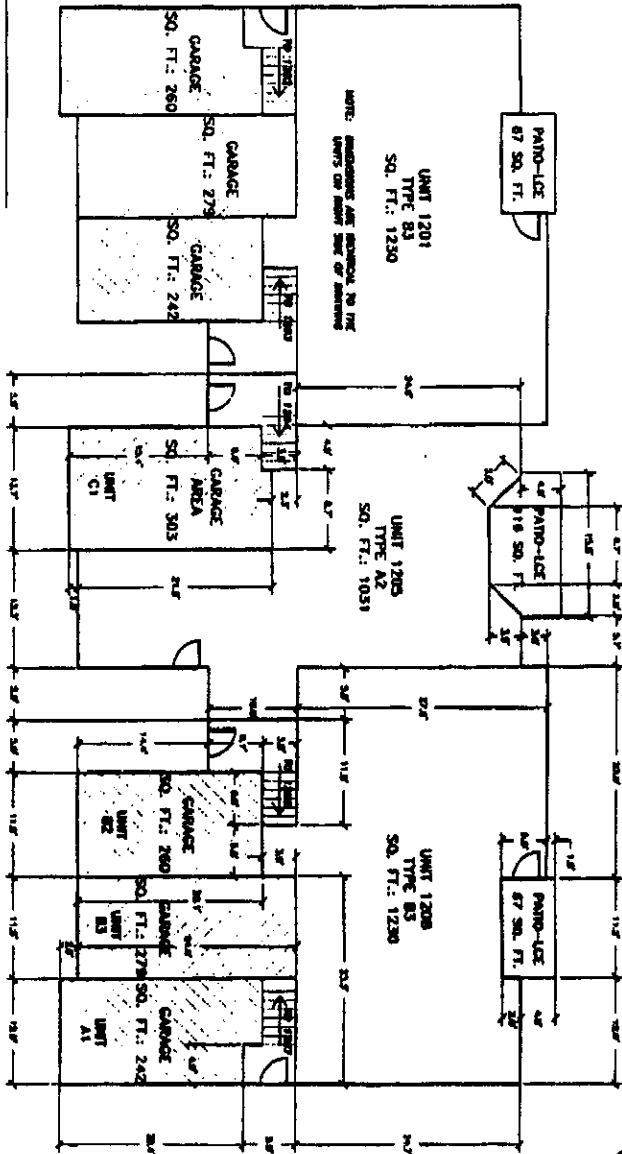

NOTES:  
 DIMENSIONS SHOWN HAVE BEEN MANUALLY  
 FIELD VERIFIED.  
 DIMENSIONS ARE MEASURED FROM THE  
 CENTER OF THE WALLS.

0 3 10 FEET  
 SCALE  
 SHEET NO. 10 - LOWER LEVEL

THE HARBOR AT PIERSON PARK CONDOMINIUMS  
 1000 PIERSON PARK  
 PLEASANTON, CALIF. 94566  
 SHEET NO. 10 - LOWER LEVEL

4781 0268

NOTES:  
 DIMENSIONS SHOWN HAVE BEEN RASIONALLY  
 FIELD VERIFIED.  
 DIMENSIONS ARE MEASURED FROM THE  
 CENTER OF THE WALLS

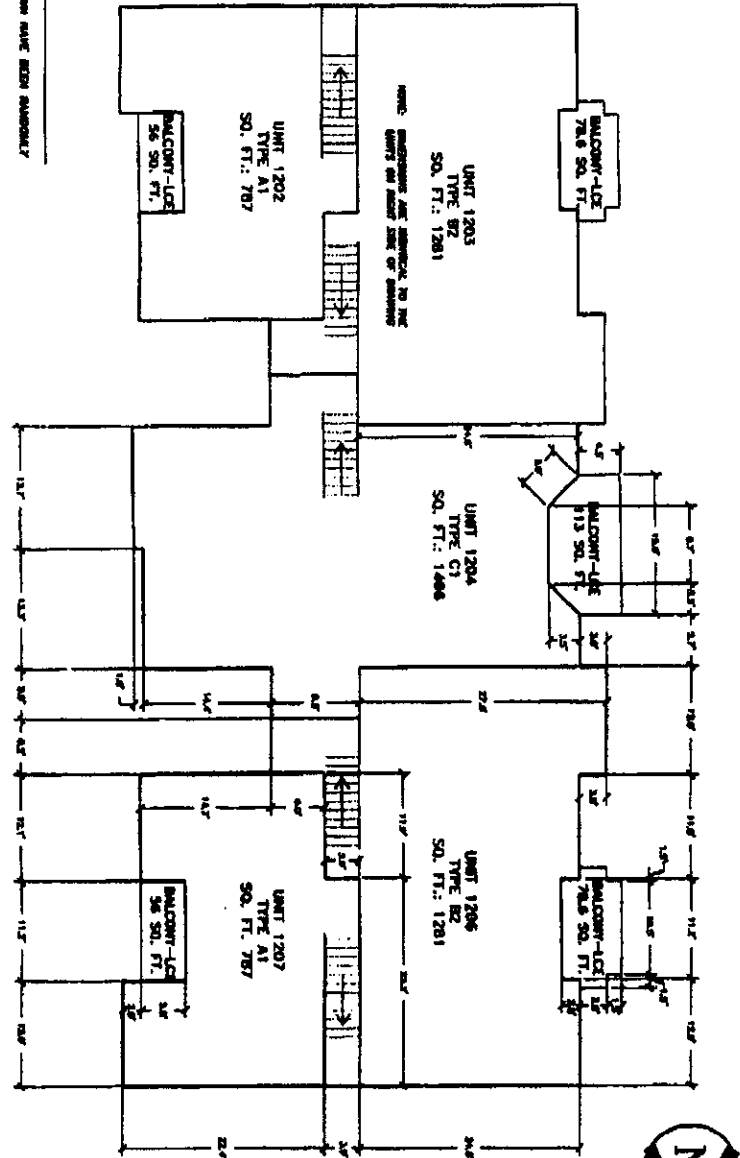

0 3 1/4 FEET  
 DIMENSION SCALE

THE ARCHITECTS OR POSITION PARK CONDOMINIUMS  
 4000 WESTERN BLVD  
 PLANO, TEXAS  
 972-8899 3000 - 03 - UPPER LEVEL

4781 0269

FILE: 0:\WORK\DWG\47810269.DWG

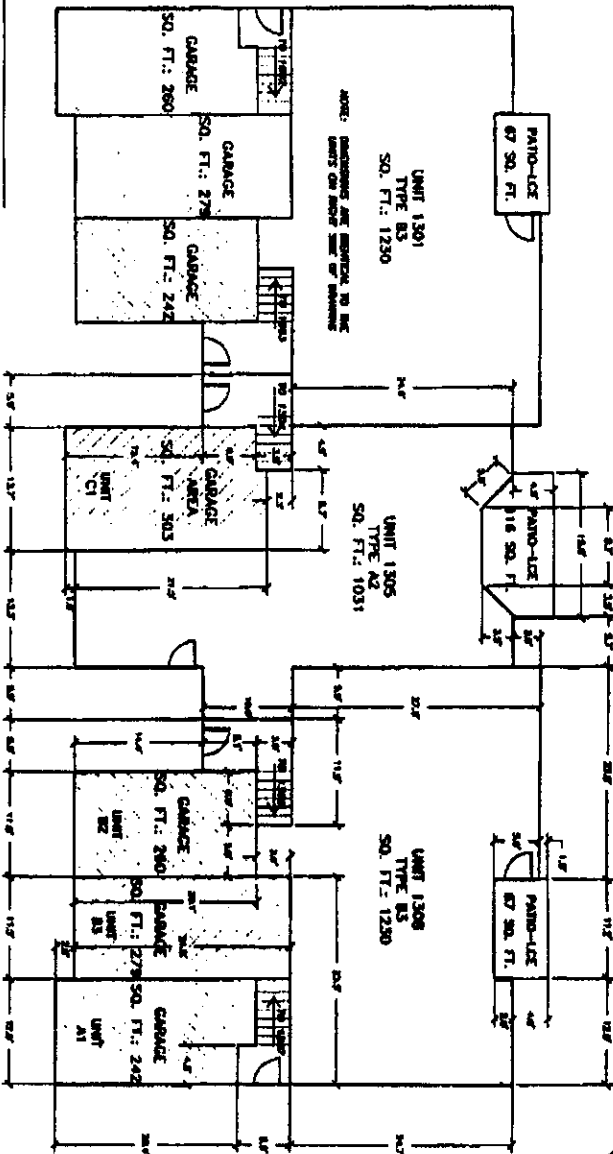

0 5 10 FEET  
PROJECT SCALE

THE MUNICIPAL OF FRIESTON PARK CONDOMINIUMS  
5501 GARDNER ROAD  
FRIESTON, VIRGINIA

BUILDING No. 12 - LOWER LEVEL

ENC Proposed Bldg. Elevation

4781 0270

FILE: D:\BPS\109\440000007.dwg

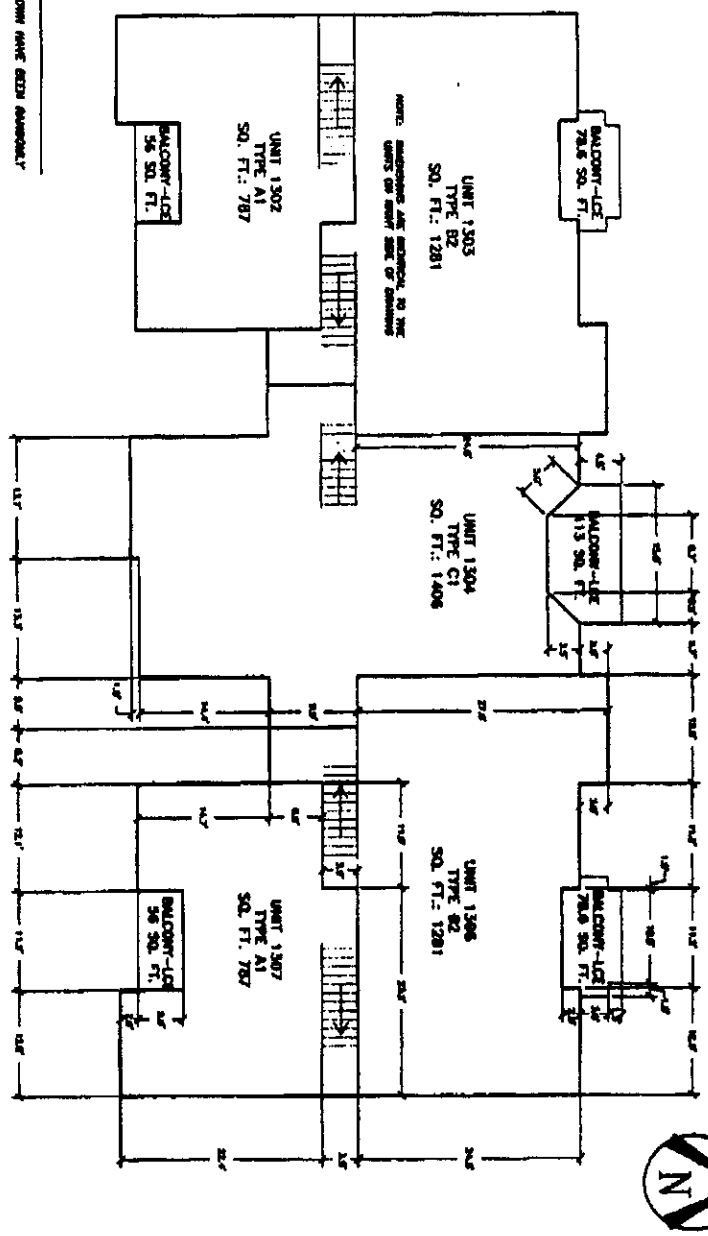

NOTES:

DIMENSIONS SHOWN HAVE BEEN APPROXIMATELY FIELD VERIFIED.

DIMENSIONS ARE MEASURED FROM THE CENTER OF THE WALLS.

1" = 5'-0" FEET  
 DIMENSIONS ARE MEASURED FROM THE CENTER OF THE WALLS

THE AREAS OF PERIMETER WALLS CORRESPONDING TO THE PERIMETER WALLS

SHALLING SH. 10 - UPPER LEVEL

4781 0271

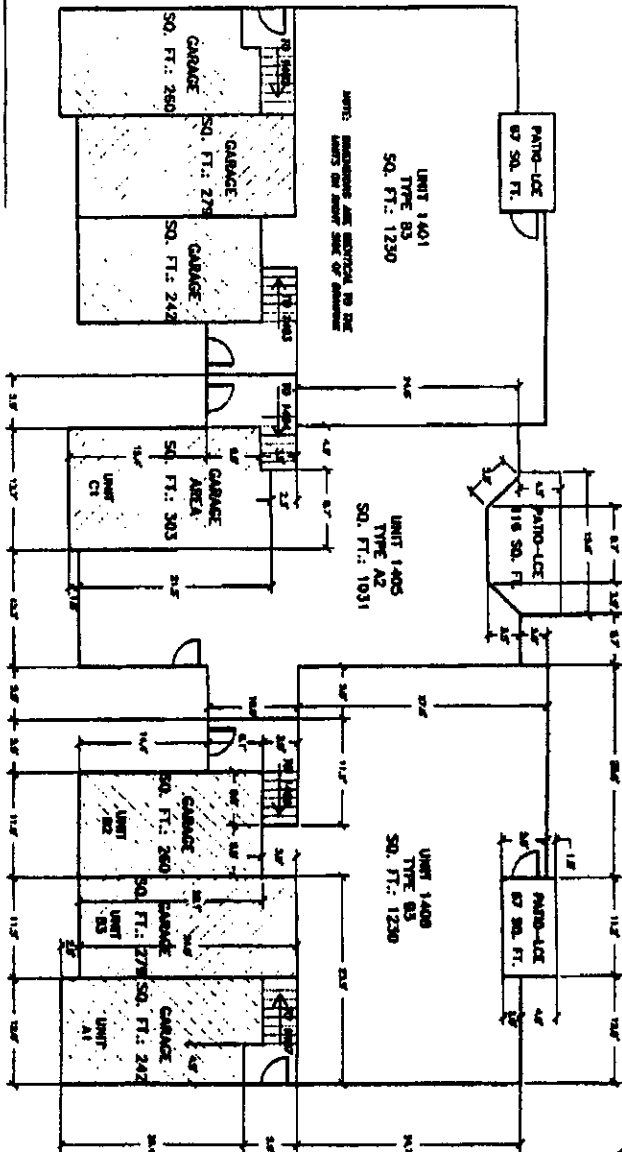

NOTES:  
DIMENSIONS SHOWN HAVE BEEN OBTAINED  
FIELD VERIFIED.  
DIMENSIONS ARE MEASURED FROM THE  
CENTER OF THE WALLS.

0 5 1/4 FOOT  
PROJECT NO. 4781 0271  
THIS PROJECT HAS BEEN APPROVED  
THE APPROVAL IS PROVIDED FROM CONSTRUCTION  
FOR THE PROJECT  
BUILDING No. 14 - LOWER LEVEL

4781 0272

FILE NO. 100-333-10-10-01

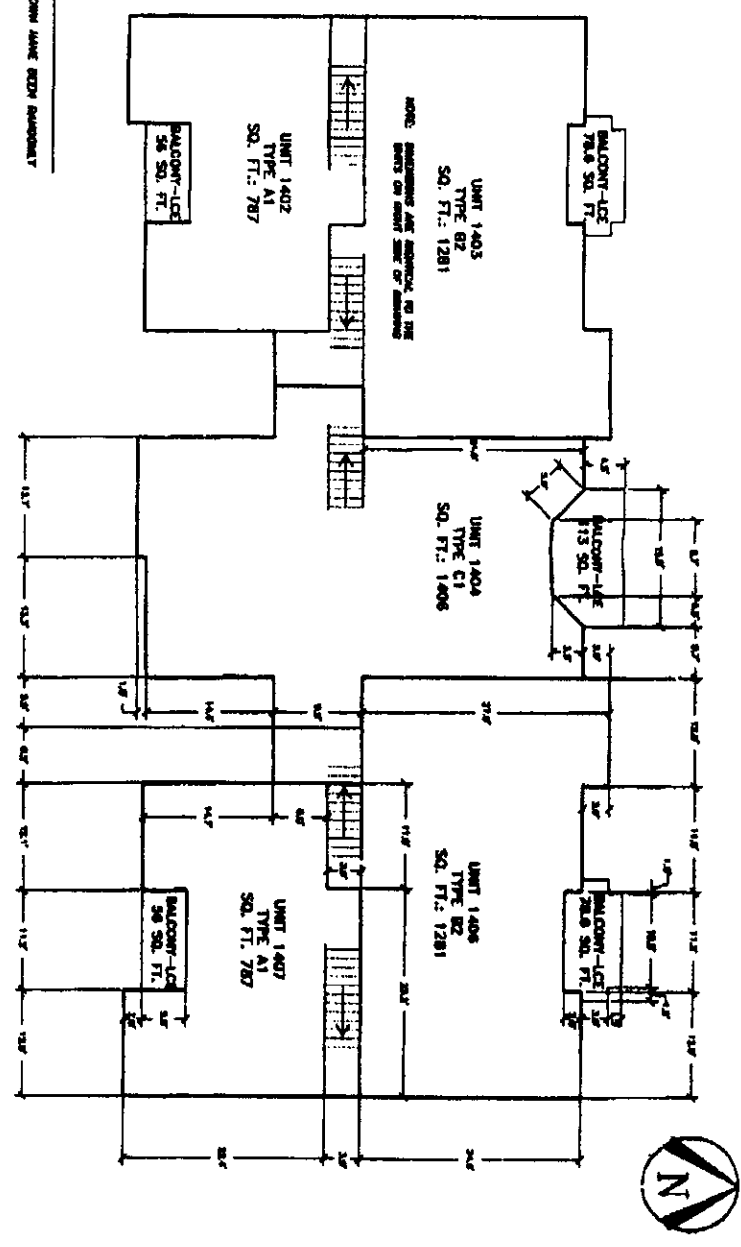

**NOTES:**  
 DIMENSIONS SHOWN HAVE BEEN MEASURED FIELD VERTICAL.  
 DIMENSIONS ARE MEASURED FROM THE CENTER OF THE WALLS.

0 5 10 FEET  
 DIMENSION SCALE  
 1/4" = 1'-0"

THE LANDLORD OR PRORATION PAIR COOPERATIVE  
 2807 SPRINGWOOD DRIVE  
 FLORISS, ILLINOIS  
 BUILDING No. 50 - UPPER LEVEL

4781 0273

NOTES:  
DIMENSIONS SHOWN HAVE BEEN MEASURED/  
FIELD VERIFIED.  
DIMENSIONS ARE MEASURED FROM THE  
CENTER OF THE WALLS

0 5 10 FEET  
DIMENSIONAL SCALE

THIS PROJECT HAS BEEN REVIEWED

THE OFFICE OF THE ARCHITECTURAL RECORDS  
HAS REVIEWED THIS  
PLAN FOR  
RECORDING PURPOSES ONLY - LOWER LEVEL

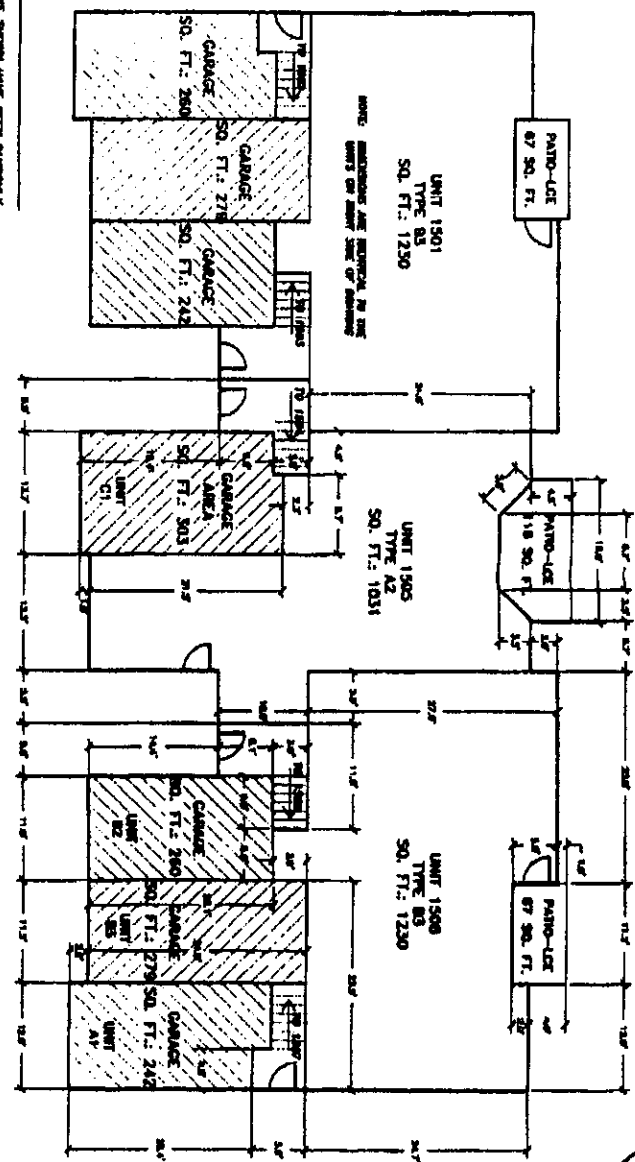

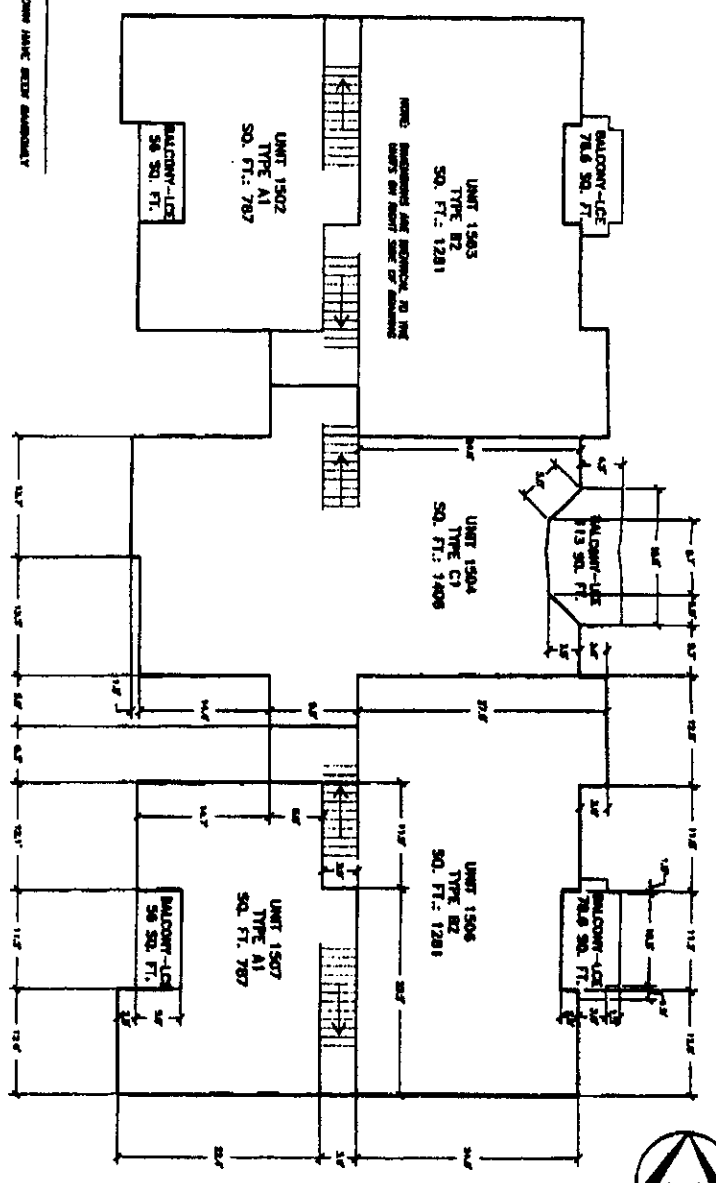



4781 0275

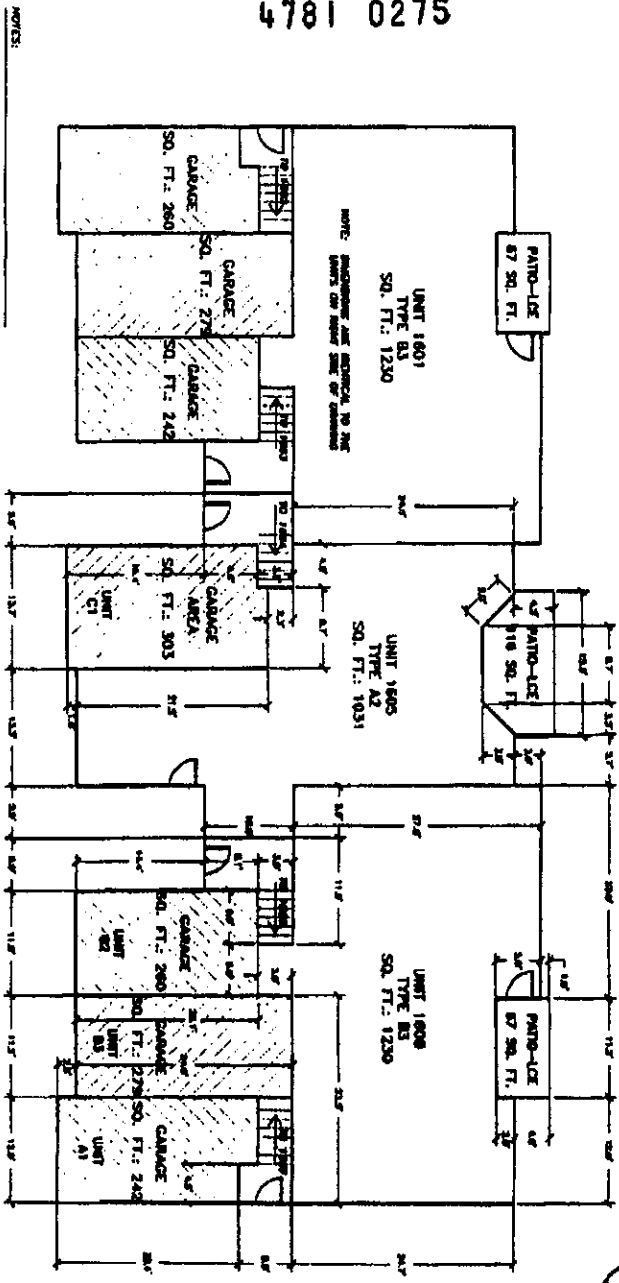

NOTES:

1. DIMENSIONS SHOWN HAVE BEEN ROUNDED UP TO THE NEAREST FOOT.

2. DIMENSIONS ARE MEASURED FROM THE CENTER OF THE WALLS.

0 TO 5 TO 10 FEET

PROJECT NO.

THE BROTHERS OF PEARSON PARK CONDOMINIUMS

504 PEARSON PARK

ALLEN, TEXAS

BUILDING NO. 30 - LOWER LEVEL



4781 0276

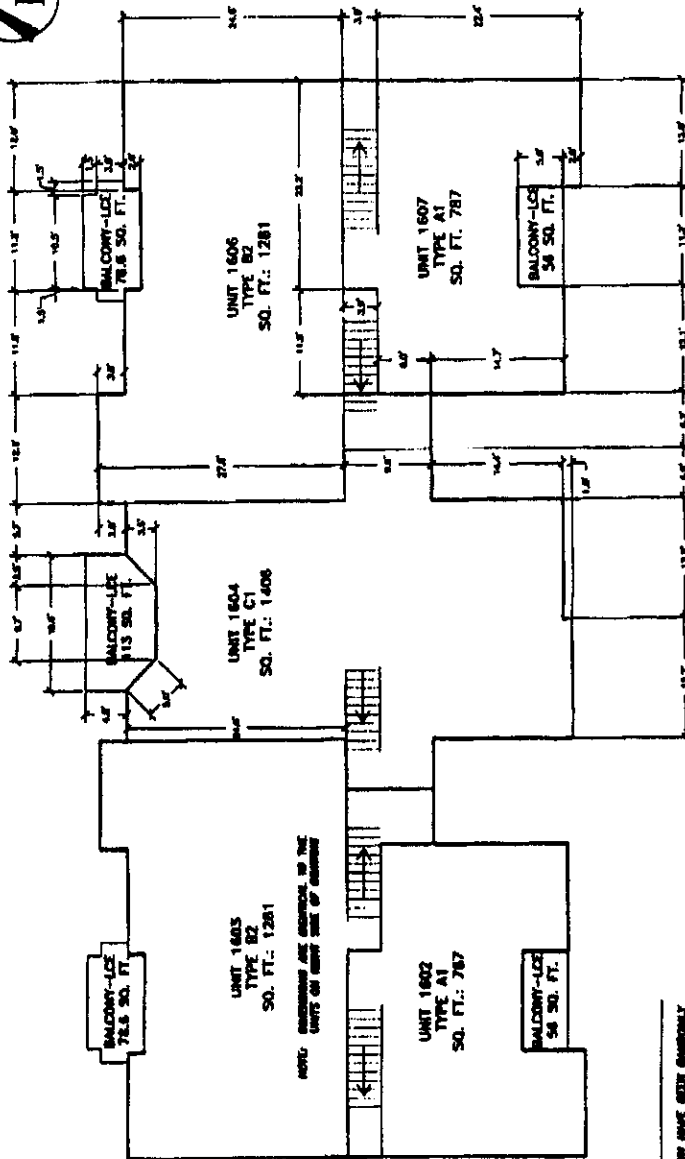

NOTE: DIMENSIONS ARE GIVEN TO THE CENTER OF THE WALLS UNLESS OTHERWISE NOTED

NOTES:  
DIMENSIONS SHOWN HAVE BEEN APPROXIMATELY  
FIELD MEASURED.  
DIMENSIONS ARE MEASURED FROM THE  
CENTER OF THE WALLS

THE INVOICES AT PRESTON PARK CONCERNING  
THE PRESTON PARK  
PLANS, TEXAS

BUILDING No. 10 - UPPER LEVEL

C. S. 10, 1977  
PRESTON PARK

1000 Preston Park, Dallas, Texas

4781 0277

<u>UNIT</u>	<u>TYPE</u>	<u>SQUARE FEET</u>	<u>% INTEREST</u>
1001	B3	1509	.880
1002	A1	1047	.610
1003	B2	1523	.888
1004	C1	1709	.995
1005	A2	1031	.601
1006	B2	1541	.898
1007	A1	1029	.600
1008	B3	1509	.880
1101	B3	1509	.880
1102	A1	1047	.610
1103	B2	1523	.888
1104	C1	1709	.995
1105	A2	1031	.601
1106	B2	1541	.898
1107	A1	1029	.600
1108	B3	1509	.880
1201	B3	1509	.880
1202	A1	1047	.610
1203	B2	1523	.888
1204	C1	1709	.995
1205	A2	1031	.601
1206	B2	1541	.898
1207	A1	1029	.600
1208	B3	1509	.880
1301	B3	1509	.880
1302	A1	1047	.610
1303	B2	1523	.888
1304	C1	1709	.995
1305	A2	1031	.601
1306	B2	1541	.898
1307	A1	1029	.600
1308	B3	1509	.880
1401	B3	1509	.880
1402	A1	1047	.610
1403	B2	1523	.888
1404	C1	1709	.995
1405	A2	1031	.601
1406	B2	1541	.898

4781 0278

<u>UNIT</u>	<u>TYPE</u>	<u>SQUARE FEET</u>	<u>% INTEREST</u>
1407	A1	1029	.600
1408	B3	1509	.880
1501	B3	1509	.880
1502	A1	1047	.610
1503	B2	1523	.888
1504	C1	1709	.995
1505	A2	1031	.601
1506	B2	1541	.898
1507	A1	1029	.600
1508	B3	1509	.880
1601	B3	1509	.880
1602	A1	1047	.610
1603	B2	1523	.888
1604	C1	1709	.995
1605	A2	1031	.601
1606	B2	1541	.898
1607	A1	1029	.600
1608	B3	1509	.880
TOTAL:		<u>171,574</u>	<u>100%</u>